

150x70mm



GE is a trademark of General Electric Company and is used under license by Bionime Corporation, No. 100, Sec. 2, Daqing St., South Dist., Taichung City 40242, Taiwan

GE est une marque de commerce de la compagnie General Électrique et est utilisée sous licence par Bionime Corporation, No. 100, Sec. 2, Daqing St., South Dist., Taichung City 40242, Taiwan

Manufacturer / Fabricant:
BIONIME CORPORATION
NO. 100, Sec. 2, Daqing Street, South District,
Taichung City, Taiwan 40242
Made in Taiwan / Fait à Taiwan

Distribution and Customer Service in Canada by/
Distribution et service à la clientèle au Canada:
Auto Control Medical
www.autocontrol.com
6695 Millcreek Drive, unit 6
Mississauga, On L5N 5R8
Toll-free/Sans frais: 1-800-461-0991

Rev. Date: 2019-01

101-3GM750-0A4
EN+FR

blood glucose
monitoring system
système de
lecture de glycémie



GE200
User's Manual
Manuel de l'utilisateur



GE is a trademark of General Electric Company and is used under license by Bionime Corporation, NO. 100, Sec. 2, Daqing Street, South District, Taichung City 40242 Taiwan (R.O.C)

Manufacturer
BIONIME CORPORATION
NO. 100, Sec. 2, Daqing Street, South District,
Taichung City, Taiwan 40242

Made in Taiwan

Distribution and Customer Service in Canada by
Auto Control Medical
www.autocontrol.com
6695 Millcreek Drive, unit 6,
Mississauga, On L5N 5R8,
Toll-free: 1-800-461-0991

Preface

Thank you for selecting the GE200 Blood Glucose Monitoring System. This manual provides all the information you need to operate this product for accurate test results. Please read this entire manual before you start any testing.

For people living with diabetes, it is important to regularly monitor blood glucose levels to effectively reduce complications from the disease. The easy-to-use GE200 Blood Glucose Monitoring System provides accurate, reliable test results to help you better manage your diabetes.

The GE200 Blood Glucose Monitoring System is designed for in vitro diagnostic use only (for single patient use and self-testing only). Testing requires only a small amount of fresh capillary whole blood from either the fingertip, palm or forearm.

The GE200 Blood Glucose Monitoring System is manufactured and supported by Bionime Corporation. If you have any questions or concerns, please contact the Auto-Control Medical Distribution and Customer Service Center toll free at 1-800-461-0991. We will make every effort to assist you.

Copyright © 2011 Bionime Corporation. All Rights Reserved Worldwide

Preface

The GE200 Blood Glucose Monitoring System is a personal blood glucose monitoring system to be used for self-testing only. It is not recommended for multiple patients.

The GE200 Blood Glucose Monitoring System is intended to be used for the quantitative measurement of glucose in fresh capillary whole blood samples drawn from the fingertips, forearm or palm. The GE200 Blood Glucose Monitoring System is intended for self-testing outside the body (in vitro diagnostic use) by people with diabetes at home as an aid to monitor the effectiveness of diabetes control. The GE200 Blood Glucose Monitoring System should not be used for diagnosis of, or screening for diabetes or for neonatal use.

A healthcare professional should be contacted when Customer Service is not available.

Please forward your warranty card:

Auto Control Medical
6695 Millcreek Drive, unit 6,
Mississauga, On L5N 5R8,
Toll-free: 1-800-461-0991

2

Caution

- Before using the GE200 Blood Glucose Monitoring System to test your blood glucose, please read all of the instructions and conduct all of the tests including the quality control test (Refer to page 37).
- Please perform the quality control test regularly to make sure the test results are accurate.
- The GE200 Blood Glucose Meter can only be used with GE200 Blood Glucose Test Strips. Other brands' test strips should not be used under any circumstances. The use of other brands' strips may give inaccurate results.
- The GE200 Blood Glucose Monitoring System is intended for in vitro diagnostic use only. The GE200 Blood Glucose test results using fresh capillary whole blood samples from the fingertip, palm and forearm are calibrated to be the equivalent to that of plasma testing.
- The GE200 Blood Glucose Monitoring System is intended for self-testing. It should not be used to diagnose diabetes mellitus.
- If the GE200 Blood Glucose Meter and Test Strips are exposed to a substantial change in temperature, please wait 30 minutes before measurement.
- Follow all environmental protection regulations when disposing of batteries.
- The GE200 Blood Glucose Meter will be set as mmol/L by default when sold in Canada. If meter display shows "mg/dL" during setting or test, please contact Auto Control Medical Distribution and Customer Service Center at 1-800-461-0991. Use of the wrong unit of measurement may cause incorrect treatment.

3

Caution

- Avoid contact with dripping or splashing liquids.
- The minimum blood sample size to test using the GE200 Blood Glucose Monitoring System is 0.75 μL : (•)

Sample Size Example



Blood sample size above 3.0 μL might contaminate the test strip port and the meter.

Blood sample size below 0.75 μL may cause an inaccurate result or may prevent a meter reading. An Er4 reading will be displayed if the sample size is too small. In this case, repeat the test with a new test strip.

Caution



Important Safety Notes:

- The GE200 Blood Glucose Meter and Lancing Device are for single patient use. Do not share them with anyone including other family members.
- All parts of the kit are considered biohazardous and can potentially transmit infectious diseases, even after following the cleaning and disinfecting procedures. Please refer to the section "Cleaning and Disinfecting Procedures" on page 47.
- Users should wash their hands thoroughly with soap and water before and after handling the meter, lancing device, or test strips.

Table of Contents

About the GE200 Blood Glucose Monitoring System	
The GE200 Blood Glucose Monitoring System.....	8
The GE200 Blood Glucose Meter.....	10
The GE200 Blood Glucose Test Strip.....	14
Before Testing	
Meter Activation and Battery Change.....	16
Setting Up Your Meter - Setting the Date, Time and Volume.....	18
Turning On/Off the Meter.....	22
Turning On/Off the Backlight.....	23
Handling the GE200 Blood Glucose Test Strip.....	24
Testing Procedure	
Getting Ready for Testing.....	26
Performing a Blood Glucose Test.....	27
Alternative Site Testing.....	32
View Window Appearance.....	34
Understanding Test Results and Messages.....	35

Table of Contents

Quality Control	
About Quality Control Testing.....	37
Performing a Quality Control Test.....	40
Understanding Control Test Results.....	42
Test Memory	
Recalling Test Results.....	43
Recalling Average Test Results.....	44
Caring for Your Meter	
Cleaning and Disinfecting Procedures.....	46
Error Messages and Troubleshooting.....	51
Limitations.....	55
Specifications.....	56
Warranty.....	58
Customer Service.....	59
Expected Blood Glucose Values Without Diabetes.....	60
Component Manufacturer Information.....	61

The GE200 Blood Glucose Monitoring System

Contents

Your GE200 Blood Glucose Monitoring System consists of several items. Please identify each item, learn its name and how it is used.

Below are the items included in your GE200 Blood Glucose Monitoring System:

1. Getting Started Guide
 2. User's Manual (includes Log Book, Warranty Card, Emergency Card)
 3. GE200 Blood Glucose Test Strip Package Insert *
 4. GE200 Control Solution Package Insert *
 5. GE200 Blood Glucose Meter (with 2 CR2032 batteries installed)
 6. GE200 Blood Glucose Test strips (10/25 pcs) *
 7. GE200 Control Solution * (available as: Normal (Level 2) and High (Level 4))
 8. GE Lancing Device *
 9. Clear Cap *
 10. Disposable Sterile Lancets (10 pcs) *
 11. Carrying Case (not shown) *
 12. Instruction for the lancing device (not shown) *
- (* Different packages have different bundled items. Some of packages might not include * items.)

8

The GE200 Blood Glucose Monitoring System

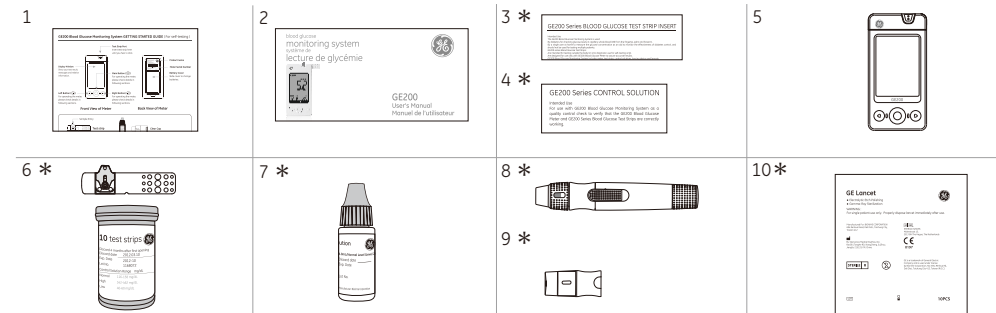

If you want to purchase optional items, please contact Auto Control Medical Distribution and Customer Service Center at 1-800-461-0991.

9

The GE200 Blood Glucose Meter

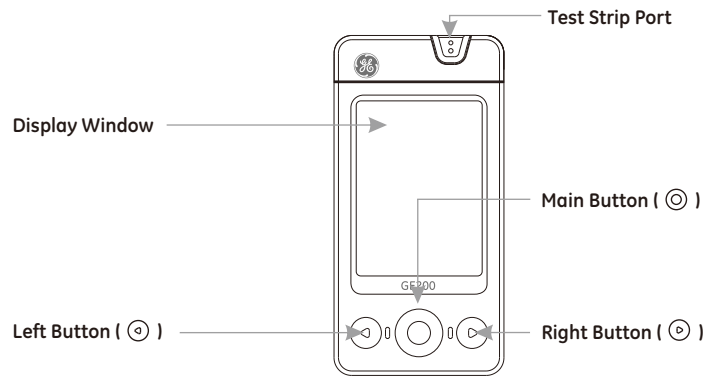

The GE200 Blood Glucose Meter

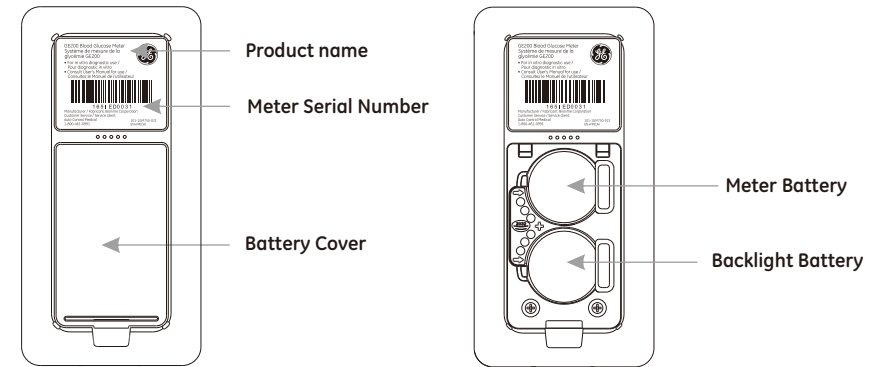

The GE200 Blood Glucose Meter

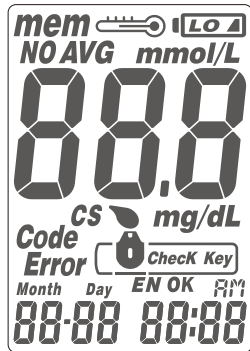

The GE200 Blood Glucose Meter

mem	Indicates a test result stored in memory		Indicates when to apply the blood sample
NO AVG	Indicates a test result not included into the average results of the meter		Appears after you insert test strip into meter
AVG	Indicates the average of the test results	Error	Appears when an error occurs
CS	Indicates a control solution test result	Month Day 88-88	Current date under time mode or testing date under memory mode
mmol/L mg/dL	Unit of test result		Warns when the operational temperature limit is exceeded during testing
888	Test result	PM	Indicates the time in 12H format
LO	Warns when the batteries are low or must be replaced	88:88	Displays current time under time mode or testing time under memory mode
OK EN Code Check Key Manufacturing use only			

The GE200 Blood Glucose Test Strip

The GE200 Blood Glucose Meter can only be used with GE200 Blood Glucose Test Strips and GE200 Control Solution. The use of other test strips or control solutions can lead to incorrect results.

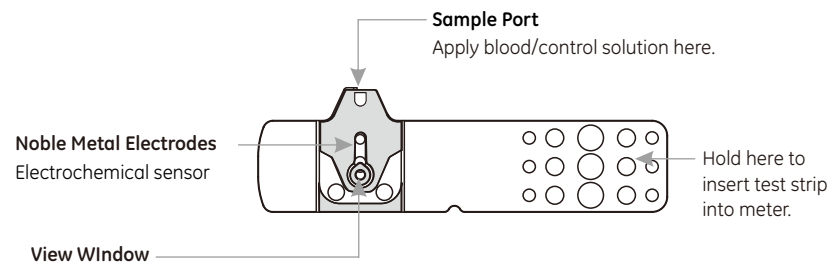

The GE200 Blood Glucose Test Strip

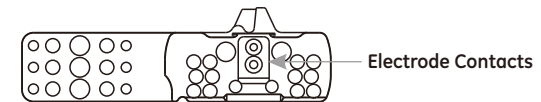

PRECAUTION

- Close the GE200 Blood Glucose Test Strip vial immediately after removing a test strip.
- Do not reuse GE200 Blood Glucose Test Strips.
- Do not use expired GE200 Blood Glucose Test Strips.
- When you open a new vial of GE200 Blood Glucose Test Strips, record the date on the vial. Discard the vial of test strips after 4 months from opening.
- Store the GE200 Blood Glucose Test Strip between 39-86°F (or 4-30°C) and in a location (< 90% relative humidity). Do not expose to direct sunlight or heat.
- If the GE200 Blood Glucose Meter and Test Strips are exposed to a substantial change in temperature, please wait 30 minutes before measurement.
- For detailed information, please refer to the GE200 Blood Glucose Test Strip Package Insert.

Meter Activation and Battery Change

Your GE200 Blood Glucose Meter comes with two CR2032, 3volt, batteries installed. Two new batteries will provide power to perform approximately 1000 tests under normal use. Press the main button or insert a strip to activate your meter.

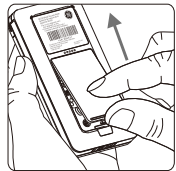

1. Turn the GE200 Blood Glucose Meter over. Press the battery cover to open.

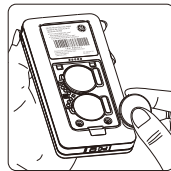

2. Install the batteries. Be sure to put the batteries in the correct direction (polarity (+) facing up).



3. Put the battery cover back until it snaps into place.

Meter Activation and Battery Change

4. The GE200 Blood Glucose Meter will enter Self-Testing Mode automatically when replacing the battery (all symbols will appear on the screen).
5. Press any button to exit the self-test and enter Setting Mode.
6. You must set the time and date when replacing the battery. See Chapter "Setting Up Your Meter - Setting the Date, Time, and Volume" on page 18. Test results are still stored in the memory.



CAUTION

- Please follow the local regulation to properly discard a used battery.

Setting Up Your Meter - Setting the Date, Time and Volume

You can enter the Setting Mode two ways.

1. Replace the Battery

After removing the battery, press the main button several times until there is no signal on screen, then follow the battery installation steps to replace battery. The GE200 Blood Glucose Meter will perform a self-test. Press the main button to exit the self-test and enter the Setting Mode.

2. With Battery Inserted

Press the main button to turn on the GE200 Blood Glucose Meter. Hold down the main button for 7 seconds. During this time the screen will go blank until you hear a beep. After the beep, the meter will turn on into the Setting Mode. The display screen will show setting data.

NOTE

- Use the Left and Right buttons to select your setting data and press the main button to confirm each selection. After confirming all of the settings, you will return to the Time Mode.

Setting Up Your Meter - Setting the Date, Time and Volume

1. Year setting

With the year format blinking, press the Left or Right button until you see the current year. Press the Main button to confirm. Once the year is confirmed, the Month Setting will appear.



2. Month setting

With the month blinking, press the Left or Right button until you see the current month. Press the Main button to confirm. Once the month is confirmed, the Day Setting will appear.



3. Day setting

With the day blinking, press the Left or Right button until you see the current day. Press the Main button to confirm. Once the day is confirmed, the Time Setting will appear.



Setting Up Your Meter - Setting the Date, Time and Volume

4. Time format 12/24H selection

With the time format blinking, press the Left or Right button to switch between 12H and 24H. Press the Main button to confirm. Once confirmed, the Hour Setting will appear.

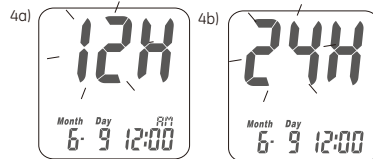

5. Hour setting

With the hour blinking, press the Left or Right button until you see the current hour. Press the Main button to confirm. Once the hour is confirmed, the Minute Setting will appear.

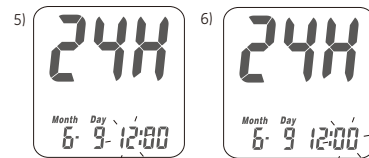

6. Minute setting

With the minutes blinking, press the Left or Right button until you see the current minute. Press the Main button to confirm. Once the minute is confirmed, the Volume Setting will appear.

Setting Up Your Meter - Setting the Date, Time and Volume

7. Volume Setting

With the volume blinking, press the Left or Right button to turn the volume on or off. Press the Main button to confirm and finish the settings.

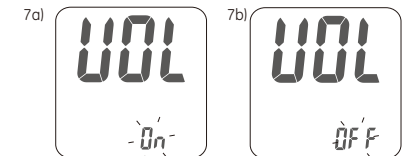

NOTE

- If you do not change any settings during Meter Set-up for over 2 minutes, the GE200 Blood Glucose Meter will leave setting mode and power off automatically.

Turning On/Off the Meter

1. How to turn on the GE200 Blood Glucose Meter

Press the Main button or Insert a test strip.

2. Manual Power off

To power off the GE200 Blood Glucose Meter, press and hold the Main button for 4 seconds.

3. Auto Power off

The GE200 Blood Glucose Meter will power off automatically after 2 minutes if no buttons are pressed or no strip is inserted.

Turning On/Off the Backlight

1. Turn on the backlight

Press and hold the Main button for 2 seconds.

2. Manually turn off the backlight

With the backlight on, press and hold the Main button for another 2 seconds.

3. Auto shutoff

The GE200 Blood Glucose Meter backlight will turn off automatically after 10 seconds if no buttons are pressed.

Handling the GE200 Blood Glucose Test Strip

How to handle the GE200 Blood Glucose Test Strip.

Inserting the GE200 Blood Glucose Test Strip:

1. Hold the GE200 Blood Glucose Test Strip between your thumb and middle finger with the view window "Ⓜ" facing up.
2. Put your forefinger on the side of the strip as shown.
3. Insert the GE200 Blood Glucose Test Strip into test strip port until it clicks and firmly stops.

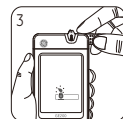
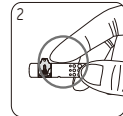
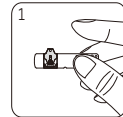

Handling the GE200 Blood Glucose Test Strip

Removing the GE200 Blood Glucose Test Strip:

1. Hold the GE200 Blood Glucose Test Strip as shown.
2. Rotate the GE200 Blood Glucose Test Strip counterclockwise and pull up simultaneously.
3. Take the GE200 Blood Glucose Test Strip out of the test strip port.
Please follow your local regulations and discard used strips properly.

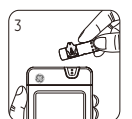
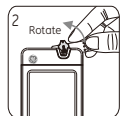

Getting Ready for Testing

Before performing a blood glucose test, prepare the items below :

- GE200 Blood Glucose Meter
- GE200 Blood Glucose Test Strips
(Please check the expiration date on the test strip vial. Do not use expired test strips)
- GE Lancing device
- Sterile lancet
- Alcohol swab (optional)

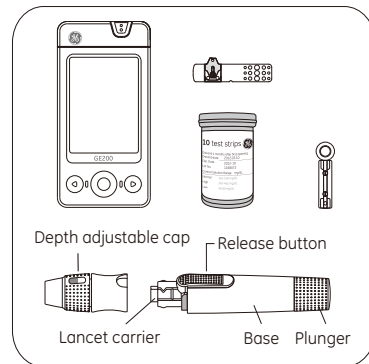

26

Performing a Blood Glucose Test

1. Hold the depth adjustable cap in one hand and hold the base in the other hand. Bend the cap towards the down side, until a gap appears between the cap and base.
2. Pull the cap and base off in opposite directions, remove the cap.
3. Insert a new disposable lancet firmly into lancet carrier.
4. Twist off and set aside the protective cover of the disposable lancet.
5. Replace the depth adjustable cap.
6. Choose a depth of penetration by rotating the top portion of the depth adjustable cap until your desired setting is visible in the window. Settings are based on skin type "▬▬▬" for soft or thin skin; "▬▬▬▬" for average skin; "▬▬▬▬▬" for thick or calloused skin.

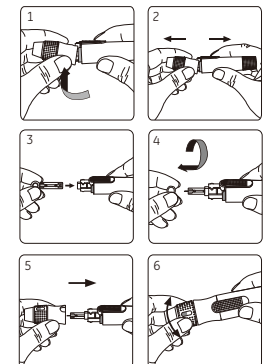

27

Performing a Blood Glucose Test

7. Hold the base in one hand and pull on the plunger with the other hand. The device will be cocked. Release the plunger and it will automatically move back to its original position near the base.
8. Wash your hands with warm soapy water and dry thoroughly.
9. Take one GE200 Blood Glucose Test Strip from the vial. Close the vial cap immediately.
10. Insert the strip into the test strip port of the GE200 Blood Glucose Meter with the view window facing up.
11. Once the strip is inserted, all symbols will appear on your meter display and will be accompanied by a beep (if volume is turned on).

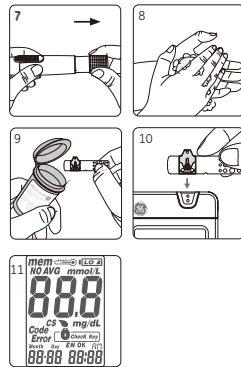

NOTE

- The GE200 Blood Glucose Meter will automatically detect the Code number on the strip. You do not have to check the Code number on the meter display and strip vial.

Performing a Blood Glucose Test

12. A blood drop icon will appear on the display window and will be accompanied by a beep (if volume is turned on). Apply the blood sample within 2 minutes.
13. Place the lancing device against your fingertip and press the release button.
14. Touch and hold the blood drop to the edge of sample port until the view window is filled with blood. If the view window is not completely filled with blood the test will not start. If the blood sample was insufficient, discard the test strip and repeat with a new GE200 Blood Glucose Test Strip.
15. Countdown Mode will begin on the display window. After 5 seconds, your test result will appear.

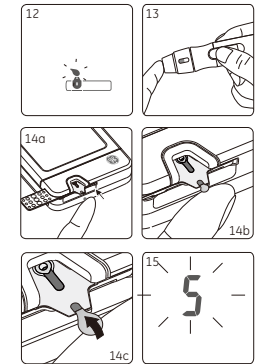

Performing a Blood Glucose Test

16. Pull off the depth adjustable cap. Without touching the used disposable lancet, insert the lancet tip into the protective lancet cover.
17. Hold the release button in one hand (see picture 17, step 1) and pull on the plunger with the other hand (see picture 17, step 2) to safely eject the used disposable lancet.
18. Discard the used disposable lancet into an appropriate puncture-proof or biohazard container.
19. Replace the depth adjustable cap after finishing the test.

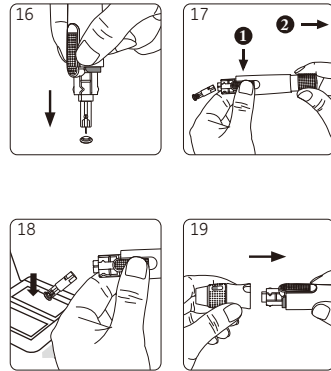

Performing a Blood Glucose Test

CAUTION

- Do not apply your blood drop to the sample port on the strip until you see the " " appear. The GE200 Blood Glucose Meter is performing an internal test and will display " " and "Error" if you apply blood too soon. If this occurs, please repeat the test with a new test strip.
- Record the opening date of a new test strip vial. Discard the vial of test strips 4 months after opening.
- Always keep the metal contacts of the test strip port clean. If any dust or impurities are present, please clean with a small, soft brush.
- The GE200 Blood Glucose Monitoring System and GE Lancing Device are intended for single patient use only. Do not share these devices with anyone, including other family members.
- All parts of this kit are considered biohazards and can potentially transmit infectious diseases, even after you have performed the cleaning and disinfecting procedure.
- Users should wash hands thoroughly with soap and water after handling the meter, lancing device, and test strips.
- Please refer to the section "Cleaning and Disinfecting Procedures" on page 47 for cleaning and disinfecting instructions.





View Window Appearance

Make sure your blood sample covers the whole area of the view window to get an accurate test result. An insufficient blood sample will result in an error message ("Er4"). If this occurs, repeat the test with a new test strip.



Insufficient blood sample

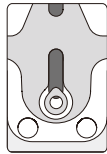

Sufficient blood sample

⚠ CAUTION

- Check the expiration date printed on the strip vial every time you use a test strip. Do not use expired GE200 Blood Glucose Test Strips.
- Use each GE200 Blood Glucose Test Strip immediately after removing it from the vial.
- Do not reuse GE200 Blood Glucose Test Strips.
- Do not perform testing immediately after moving from one ambient temperature to another (e.g. after coming indoors from the outside). Allow 30 minutes for the temperature of the meter and the test strips to equilibrate.
- Apply the blood sample only on the sample port of the test strip.

Understanding Test Results and Messages

Blood glucose test results are shown on the GE200 Blood Glucose Meter as mmol/L.

If your blood glucose result is unusually high or low, or if you question your test results, repeat the test with a new GE200 Blood Glucose Test Strip.

You can also run a Quality Control Test with the GE200 Control Solutions to check your GE200 Blood Glucose Meter and GE200 Test Strip (Refer to "Performing a Quality Control Test" on page 40).

If the test result still remains unusually high or low, contact your healthcare professional immediately.

If you are experiencing symptoms that are not consistent with your blood glucose test results and you have made sure to follow all instructions in this manual, contact your healthcare professional immediately.

Follow local regulations or consult your health care provider for appropriate disposal of used test strips and lancets.

Understanding Test Results and Messages

The GE200 Blood Glucose Meter displays results between 1.1 and 33.3 mmol/L.

If the test result is below 1.1 mmol/L, "Lo" will appear on the screen. Please repeat your test with by a new test strip.

If you still get a "Lo" result, contact your healthcare professional.

If the test result is above 33.3 mmol/L, "Hi" will appear on the screen. Please repeat your test again with a new test strip.

If you still get a "Hi" result, contact your healthcare professional.

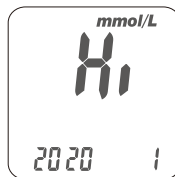

What is a Quality Control Test ?

To ensure proper monitoring function, it is necessary to regularly perform a quality control test. Use one of the GE200 Control Solutions when testing your GE200 Blood Glucose Monitoring System in the Control Solution Mode. If the test result is within the Control Solution Range printed on the strip vial label, the GE200 Blood Glucose Monitoring System passes the Quality Control Test and your GE200 Blood Glucose Monitoring System is working properly.

Control Solution Range:

Example of Control Solution Range printed on your test strip vial label.

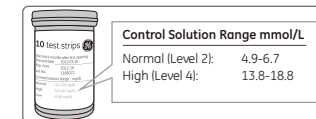

NOTE

- If you want to purchase control solutions (Level 2 or Level 4), please contact the Auto Control Medical Distribution and Customer Service Center toll free at 1-800-461-0991.

About Quality Control Testing

When should a Quality Control Test Be Performed ?

- To ensure that your GE200 Blood Glucose Meter and GE200 Blood Glucose Test Strip are working properly.
- To confirm that you are following the correct testing procedures.
- To prepare for your initial blood glucose test.
- To check the GE200 Blood Glucose Test Strip when you open a new vial of strips.
- To check your GE200 Blood Glucose Meter after it has been dropped, damaged or exposed to liquids.
- If you suspect that your test results are inaccurate, or if your test results are not consistent with the way you feel.
- To practice testing.

Required Items for Quality Control Tests

To perform a quality control test, prepare the items below :

- GE200 Blood Glucose Meter
- GE200 Blood Glucose Test Strips
- GE200 Control Solution

About Quality Control Testing



CAUTION

- Each time you open a new bottle of control solution, write the expiration date on the label. The GE200 Control Solution is good for 3 months after opening the bottle, or until the expiration date printed on the label, whichever comes first.

Example



- Wipe the bottle cap with a clean tissue before tightly closing the bottle of control solution.
- Close the bottle of control solution tightly immediately after using.
- Check the expiration date before use. (Refer to the GE200 Control Solution Package Insert).
- Keep control solution bottles out of reach of children.

Performing a Quality Control Test

1. Take one GE200 Blood Glucose Test Strip from the vial and close the vial cap immediately.
2. Insert the GE200 Blood Glucose Test Strip horizontally (not vertically) with the colored view window facing up into the test strip port.
3. While the blood drop icon is flashing on the display window, press and hold the Main button for at least 3 seconds until the "CS" and "L2" symbol appears.
4. Keep pressing the main button for another 3 seconds to select the "CS" level you to test: Level 2-Normal, Level 4-High. Ensure that the control solution level on the control solution bottle matches the level you are testing.
5. You will see the blinking " " icon and "CS" icon on the screen, prompting you to apply the corresponding level of GE200 Control Solution.
6. Shake the bottle of GE200 Control Solution well before opening the cap. Place the cap on a flat surface.
7. Place a drop of control solution onto the top of the cap.
8. Gently touch the sample port of the strip with the control solution from the top of the cap.
9. The screen will display the count time starting from 5 (you will hear a beep if the volume is turned on).

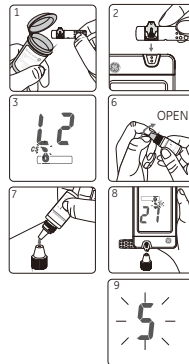

40

Performing a Quality Control Test

10. Tightly replace the cap on the GE200 Control Solution bottle.
11. The control solution result will appear. Compare your Quality Control Test result to the Control Solution Range printed on the GE200 Blood Glucose Test Strip vial label.

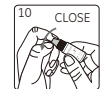

CAUTION

- Your Control Solution Test results will not be included in the average calculations, however, they can still be recalled and viewed. The Control Solution Test result will be shown with the "CS" icon on the screen.
- The Control Solution Test should be conducted between 43-111°F (6-44°C).
- Before " " and "CS" appear, do not touch the control solution to the sample port on the strip. The GE200 Blood Glucose Meter is performing an internal check. Touching the control solution to the sample port before prompted will result in an error message: "Error" and " " and be accompanied by beeps (if volume is turned on).
- Do not drip the control solution on to the sample port of the test strip directly. The reagent on the strip might leak into the bottle of control solution and may cause the degeneration of the control solution.
- This could contaminate the meter via the test strip port.
- Keep the test strip port clean and dry. Clean immediately if the test strip port is stained or is overly exposed to moisture.
- Do not touch the tip of the control solution bottle. If the tip is touched, clean with water.



41

Understanding Control Test Results

Your control solution test results should fall within the control solution range printed on the test strip vial label. If the results are within the range, the GE200 Blood Glucose Monitoring System is working correctly.

Example of control solution range printed on your test strip vial label.

Control Solution Range	
L2 = Level 2 (Normal)	L4 = Level 4 (High)
4.9 ~ 6.7 mmol/L	13.8 ~ 18.8 mmol/L

Possible reasons your Control Solution results are out of the range :

- Your GE200 Control solution is expired or was first opened more than 3 months ago.
- Your GE200 Blood Glucose Test Strip has expired.
- You left the cap of the Blood Glucose Test Strip vial or the control solution off for a period of time.
- You did not perform the test procedure correctly.
- The GE200 Blood Glucose Meter or GE200 Blood Glucose Test Strip have malfunctioned.

If GE200 Control Solution results are out of range, your GE200 Blood Glucose Monitoring System may not be working properly. Repeat the Quality Control Test. If your control solution results are still out of range, do not use GE200 Blood Glucose Meter to test your blood glucose. Please contact the Auto Control Medical Distribution and Customer Service Center toll free at 1-800-461-0991.

42

Recalling Test Results

The GE200 Blood Glucose Meter is able to automatically store a maximum of 1000 test results with time and date.

If your meter has stored 1000 results, the newest test result will replace the oldest one.

To recall your test memory, start the meter without a test strip inserted.

1. Press the Main button to switch from the Time Mode to Memory Mode. You will see the "mem" icon in the upper left corner of the display. The latest test result will appear with the number "1".
2. Use either the Left or Right button on the side to review all previous results with date and time. Results display from the most recent (Sequence no. "1") to the oldest (Sequence no. "1000") in the lower right hand corner of the screen.
3. The Quality Control Test result can be recalled from the saved data. When "CS" appears next to the data, the test was performed using the GE200 Control Solution. The control solution test result will not be used when recalling test average results.

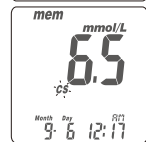
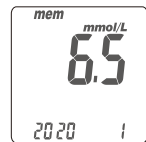

43

Recalling Average Test Results

The GE200 Blood Glucose meter provides several average test results. View the 1-day, 7-days, 14-days, 30-days, 60-days and 90-days average test results for better blood glucose monitoring.

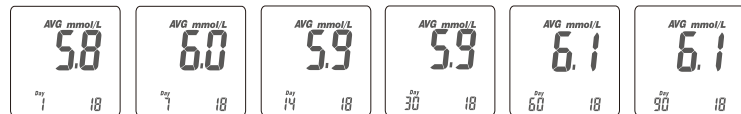

1. Press the Main button to switch the screen to Average Mode.
2. On the average screen, use either the Left or Right button to view 1-day, 7-days, 14-days, 30-days, 60-days or 90-days averages.
3. The number shown in the lower right hand corner indicates how many test results have been calculated.
4. Excluding test results from the average calculation:
You may exclude the test result from average calculation right after each test.
You have to perform this exclusion immediately after the meter displays the reading of your test result. Press the Right button until the symbol "**NO AVG**" appears in the upper right of the screen. Keep pressing the Right or Left button while simultaneously pressing the Main button until "**NO AVG**" appears. The test result is now excluded from averaging.

44

Recalling Average Test Results

To recover excluded test results and include them in the average calculation, do not leave the current mode. Press the Right or Left button until the symbol "**NO AVG**" changes to "**AVG**". Keep pressing the Right or Left button and while simultaneously pressing the Main button until "**AVG**" appears. The excluded test result is now included into the average calculation.

5. Quick Searching:

To view test results in sequential order automatically, enter the Memory Mode. Press the Right or Left button for 2 seconds. (The Right button is for viewing from the most current to the oldest test results. The Left button is for viewing from the oldest to the most current test results). Release the button to stop at any particular test result.



NOTE

- The Average function requires that the correct time and date is set. Test results must exist during the desired time interval. For example: To get a 14-day average on 1/30, you must have test results dated between 1/17 and 1/30. If no test results exist during that time frame you will not receive an average.
- To exclude test results from average calculation, you need to remain in Test Mode and perform the exclusion right after you get the test result. Once you move to MEM Mode, Average Mode or Time Mode, you will not be able to perform the exclusion.
- The "Lo", "Hi" results, control solution test results will be excluded from average calculations.

45

Caring for Your Meter

Maintenance

Keep your meter and test strip free of dust, water or any other liquid. Store the meter in the carrying case when not in use. If your meter is dropped or damaged, perform a quality control test with the control solution before performing a blood glucose test.

Cleaning Meter

Clean the outside of the meter with a damp cloth and mild soap/detergent. Do not get the test strip port wet.

Cleaning Test Strip Port

If your test strip port is stained with blood, control solution or any liquid, please use a dry tissue or alcohol swab to clean it immediately. Do not use anything wet to clean it. Perform a quality control test to ensure the GE200 Blood Glucose Meter is working properly.

Cleaning and Disinfecting Procedures

Indirect transmission of Human Immunodeficiency Virus (HIV), Hepatitis B Virus (HBV) and Hepatitis C Virus (HCV) during the delivery of healthcare services has been increasingly reported. Persons using blood glucose monitoring systems have been identified as one risk group due to the shared use of fingerstick (lancing) devices and point of care blood testing devices.

The cleaning procedure is to remove dust, blood and body fluid from the surface and should be performed whenever the meter or lancing device is visibly dirty. Performing the cleaning procedure once per week is recommended. The disinfecting procedure is necessary to kill pathogens such as HIV, HBV and HCV on the device. This procedure should be performed periodically; once per week is recommended.

If the meter is being operated by a second person who is providing testing assistance to the user, the meter and lancing device should be decontaminated prior to use by the second person. NOTE: the cleaning procedure can only remove visible contaminants from surfaces. Only the disinfecting procedure can eliminate non-visible pathogens.

CaviWipes Disinfecting Towelettes has been tested and may be used to clean and disinfect the meter and lancing device. Users may purchase the disinfecting wipes from the manufacturer (Metrex), distributors or major on line retail sites such as amazon.com.

Cleaning and Disinfecting Procedures



NOTE

- Clean and disinfect the outside of the device only. Do not remove battery cover when cleaning and disinfecting.

To clean the meter:

1. Thoroughly wipe the entire surface of the meter with disinfecting wipes listed above to clean any possible dirt, dust, blood and other body fluids.

To disinfect the meter:

2. Take another disinfecting wipe and wipe the meter thoroughly. (Note: All blood and body fluids should be cleaned from surface before performing the disinfecting procedure)

3. Allow the surface to remain wet for 2 minute.

4. Allow to air dry.

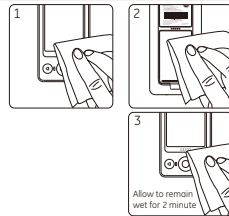

Cleaning and Disinfecting Procedures

To clean the lancing device:

1. Thoroughly wipe the entire surface of the lancing device with disinfecting wipes listed above to clean any possible dirt, dust, blood and other body fluids.

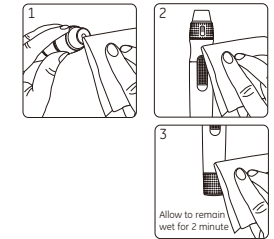

To disinfect the lancing device:

2. Take another disinfecting wipe and wipe the Lancing device thoroughly. (Note: All blood and body fluids should be cleaned from surface before performing disinfecting procedure)

3. Allow the surface to remain wet for 2 minute.

4. Allow to air dry.



NOTE

- Your GE Lancing Device has been tested to ensure that there is no change in the performance of the device after 550 cleaning cycles and 550 disinfecting cycles. The testing simulates 2 cleaning and disinfecting cycles per week over the typical life of the meter (5 years).

Cleaning and Disinfecting Procedures

CAUTION

- Users should wash their hands thoroughly with soap and water after handling the meter, lancing device or test strips.
- Please examine your LCD screen, test strip port, buttons and surface of your meter and lancing device after cleaning and disinfecting cycles. Stop using the meter and/or lancing device if any of the following occur:
 - Thin, silver streaks appear on the screen,
 - The screen becomes cracked, soft, dissolved, brittle or swollen.
 - You are unable to turn on/off your meter, operate the right / left button, the lancing device release button or depth adjustable cap.
 - You are unable to enter meter settings, function modes or recall your testing results.

If you have any questions or concerns, please contact your GE200 Blood Glucose Monitoring System authorized representative or call the Auto Control Medical Distribution and Customer Service Center toll free at 1-800-461-0991.

Error Messages and Troubleshooting

Temperature Error

1. In order to get accurate testing results, please test between 6-44°C (43-111°F).
2. When the temperature is below 6°C (43°F) or over 44 °C (111 °F), the meter will not function and the " **Error** " symbol will blink.
3. If the GE200 Blood Glucose Meter and Test Strips are exposed to a substantial change in temperature, please wait 30 minutes before measurement.



Error Messages and Troubleshooting

Battery Error

1. The "🔋" and "Error" symbols appear and the meter will not function when the battery is low. Change the batteries immediately.



NOTE

- The backlight function operates off of its own battery source. If the backlight is no longer functioning, replace the backlight battery (Refer to page 11 to find the location of the backlight battery)
- When the backlight no longer operates, the meter will still function for testing purposes until the "🔋" and "Error" symbols appear as described above.

Strip Error

1. When the test strip is inserted incorrectly, the meter will beep 4 times while the "🔋" flashes. Do not apply a sample on the test strip. Please re-insert the unused test strip correctly.
2. If, the "🔋" and "Error" symbols appear on the screen, it means the GE200 Test strip has been inserted incorrectly more than twice. Please, re-insert the unused test strip again after reviewing the steps on how to insert a test strip correctly on page 24 or call Customer Service for support. This error message can also indicate that you may have used the wrong test strips. Please check the test strip vial to ensure you are using the GE200 Test strips.

Sampling Error

Please do not apply the blood to the sample port of the test strip before the meter displays "🩸". Discard the test strip if the meter shows "Error".

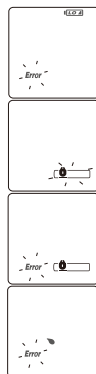

Error Messages and Troubleshooting

- Er1** - The inserted test strip has been used or damaged. Please use a new test strip.
- Er2** - The meter has malfunctioned. Do a Quality Control Test or reinstall the batteries to check if the meter works properly.
- Er3** - The signal transmission is disrupted. Repeat the test using a new test strip.
- Er4** - The blood sample volume is insufficient. Repeat the test using a new test strip.
- Er5** - An issue calibrating the Meter has occurred. Please follow the steps below:
- (1) Remove the test strip from the meter.
 - (2) Turn off the meter (press and hold the Main button for 4 seconds).
 - (3) Press the main button one more time to turn the meter back ON.
- If after turning on the Meter, you do not see Er5, your meter is functioning properly and able to perform a test.

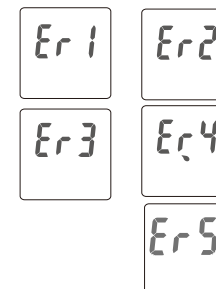

Meter Malfunction

If the GE200 Blood Glucose Meter will not turn on, please follow the steps below:

1. Open the battery cover and remove the batteries.
2. Wait for 5 minutes and reinsert the batteries as described as instructed on page 16, (Meter Activation and Changing the Battery). The meter should work normally after finishing the above steps. If one of the above error messages still appears, please contact Auto-Control Medical Distribution and Customer Service Center at 1-800-461-0991.

Error Messages and Troubleshooting

CAUTION

A blood sample should ONLY be applied to the test strip after the test strip has been inserted correctly and the Meter's screen is showing the image of the test strip and a blood drop flashing symbol. If the blood drop flashing symbol is NOT showing on the screen, do not apply a sample to the test strip. Please re-insert the unused test strip correctly. Please consult your User Manual and/or contact Customer Service for support on how to correctly insert a GE200 Test strip.

- ## Limitations
- GE200 Blood Glucose Monitoring System is not intended for serum or plasma testing.
 - Inaccurate test results may be obtained at altitudes greater than 10,000 feet (3,048 meters) above sea level.
 - Severe dehydration and excessive water loss may cause inaccurately low results.
 - High concentrations of Ascorbic acid ≥ 0.28 mmol/L, Xylose ≥ 1.33 mmol/L, Uric acid ≥ 1.19 mmol/L.
 - Not for neonatal use.
 - Not for screening or diagnosis of diabetes mellitus.
 - Not for use on critically ill patients in shock, dehydrated patients or hypo-osmolar patients.
 - Alternative site testing (AST) should only be performed during steady-state times (when glucose is not changing rapidly).
 - Alternative Site Testing should not be used to calibrate continuous glucose monitoring systems (CGMS).
 - Alternative site testing should not be performed if testing for hypoglycemia (Low blood glucose).
 - Results from alternative site testing should not be used in insulin dose calculation.

Specification

Measurement Technology	Dehydrogenase Electrochemical Sensor
Sample	Capillary whole blood
Minimum Sample Volume	0.75 microliters
Measuring Range	1.1 - 33.3 mmol/L
Test Time	5 seconds
Memory Capacity	1000 blood glucose test results with date and time
Power Saving	Turns off automatically 2 minutes after last user action. To turn off manually, press the button "Ⓞ" for 4 seconds.
Operating Temperature	43 - 111°F (6 - 44°C)
Operating Relative Humidity	10 - 90%

56

Specification

Hematocrit	20-60%
Power Supply	Two CR2032 Batteries
Battery Life	Approximately 1000 standard tests
Meter Dimension	96 mm x 46 mm x 17.5 mm
Meter Weight	65 ± 5g with batteries
Monitor	LCD
Display Area	55 mm x 37 mm
Meter Storage Conditions	-10 - 60°C (14 - 140°F)
Test Strip Storage Conditions	4 - 30°C (39 - 86°F), < 90% relative humidity

57

Warranty

Bionime Corporation warrants that this product will be free from defects in materials and workmanship for five years from the date of purchase.

This warranty does not apply to the performance of a GE200 Blood Glucose Meter that has been altered, misused, tampered with or abused in any way.

This warranty applies only to the original purchaser of the GE200 Blood Glucose Monitoring System.

Please complete and return the enclosed warranty card.

Different models have different specifications. This warranty applies only to the GE200 Blood Glucose Monitoring System; other models are not covered with this warranty card.



NOTE

- During blood glucose measurement, the GE200 Blood Glucose Meter itself may come into contact with blood. All parts of the GE200 Blood Glucose Monitoring System are considered biohazardous and can potentially transmit infectious diseases. Please follow your local regulations to properly dispose of the used GE200 Blood Glucose Monitoring System after removing the batteries.

Customer Service

Please review all of the instructions to make sure you are performing the steps correctly. If you have any questions or concerns, please contact the Auto-Control Medical Distribution and Customer Service Center at 1-800-461-0991. We will make every effort to assist you.

Expected Glucose Values Without Diabetes

Expected glucose values without diabetes ⁽¹⁾

Status	Range (mmol/L)
Fasting	<5.6
Two Hours after meals	<7.8

References

1) American Diabetes Association: Standard of Medical Care in Diabetes 2011, Diabetes Care, Vol.34, supplement 1, S11-S61, January 2011.

Component Manufacturer Information

Blood Glucose Meter, Test Strip, Control Solution

Manufacturer: Bionime Corporation
NO. 100, Sec. 2, Daqing Street, South District, Taichung City, Taiwan 40242
Product complies with *in vitro* Diagnostic Medical Device Directive 98/79/EC. (CE0197)
EC-Rep: Bionime GmbH, Tramstrasse 16, 9442 Berneck, Switzerland
E-mail: info@bionime.ch

Lancing Device

Manufacturer: Bionime Corporation
NO. 100, Sec. 2, Daqing Street, South District, Taichung City, Taiwan 40242
Product complies with Medical Device Directive 93/42/EEC
EC-Rep: Bionime GmbH, Tramstrasse 16, 9442 Berneck, Switzerland
E-mail: info@bionime.ch

Disposable Sterile Lancets

Manufacture information is as package printed.